

concluded that, in the aqueous solution of pyridoxal, the hemiacetal form predominates in the whole pH range because of its high stability.¹⁶

In Table II the spectral data of 3-hydroxypyridine-4-aldehyde are compared with those of 5-desoxypyridoxal and pyridoxal. It is seen that for these three compounds, the locations of the absorption maxima of each species are quite similar, whereas the predominant species of pyridoxal at each pH is entirely different from those of the other two compounds. In the absence of the hydroxymethyl group in the 5-position, the amount of the unhydrated form increases as the pH of the solution is raised, and, at high pH , only the unhydrated form exists. On the other hand, in pyridoxal, only the cyclic hemiacetal form is present in acidic solutions and predominates even in basic solution.

This difference may be explained as follows: since the hydroxymethyl group is electron-attracting, the double bond character of the C=O bond of the aldehyde next to the hydroxymethyl group increases. As stated before, this favors the hydra-

(16) This result is favorable for the determination of imine formation constants from spectroscopic data, since the imine band is located at $380\sim 400\text{ m}\mu$ where no absorption of pyridoxal exists.

tion of the aldehyde group. Then, dehydration proceeds to form the hemiacetal as

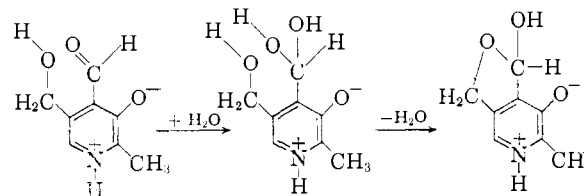

Table II compares the ionization constants of all the pyridine aldehydes studied spectroscopically. It is noted that pK_1 is always smaller in the 2-aldehyde than in the 4-aldehyde derivatives. The constant pK_1 involves the ionizations of the pyridinium hydrogen (I \rightarrow III) and hydroxyl hydrogen (I \rightarrow II). The former ionization is favored by the electron-attracting inductive effect of the hydrated aldehyde group, which is stronger in the *ortho* than in the *para* position. The latter ionization also proceeds more easily in the 2-aldehyde than in the 4-aldehyde since the dipolar hydrated form II of the former is stabilized by an intramolecular hydrogen bond of the type, $N^+-H \cdots O^-$.
WORCESTER, MASSACHUSETTS

[CONTRIBUTION NO. 2450 FROM GATES AND CRELLIN LABORATORIES, CALIFORNIA INSTITUTE OF TECHNOLOGY]

Photochemical Experiments in Rigid Media at Low Temperatures. I. Nitrogen Oxides and Ozone

By WILLIAM B. DEMORE AND NORMAN DAVIDSON

RECEIVED MARCH 31, 1959

An apparatus for studying the photolysis of substrate molecules in suspension in a frozen inert matrix at 20°K . (or 4°K .) is described. The progress of the reaction can be followed by visible-ultraviolet and by infrared spectrophotometry. Photolysis of O_3 in a nitrogen matrix at 20°K . with ultraviolet light gives N_2O . The mechanism is: $\text{O}_3 + h\nu \rightarrow \text{O}_2 + \text{O}^*$, $\text{O}^* + \text{N}_2 \rightarrow \text{N}_2\text{O}$, where O^* is an excited oxygen atom, probably $\text{O}(^1\text{D})$. (However, the possibility that the reaction is due to O^3P atoms with excess translational energy is not fully excluded.) Photolysis of O_3 in the presence of NO_2 gives the free radical NO_2 , as well as N_2O_5 and NO . Photolysis of O_3 in the presence of N_2O causes the hot atom reaction $\text{O}^* + \text{N}_2\text{O} \rightarrow 2\text{NO}$. Hot atom chemistry and transient local melting phenomena are very important for the photochemistry of rigid media at low temperatures.

There has been considerable recent interest in efforts to prepare and identify unstable species trapped in rigid solvents at low temperatures.¹⁻⁷

Some of our experiments in the field are reported in this and in the following paper. We have not been successful in producing (and identifying) many free radicals. However, several interesting and unexpected chemical reactions have been observed upon irradiation of various photosensitive substrates trapped in a nitrogen matrix at 20°K . These observations provide insight into the general features of photochemical processes in such low temperature rigid media.

(1) F. O. Rice and M. Frearno, *THIS JOURNAL*, **73**, 5529 (1951).

(2) I. Norman and G. Porter, *Proc. Roy. Soc. (London)*, **A230**, 399 (1955).

(3) H. P. Broida and J. R. Pellam, *Phys. Rev.*, **95**, 845 (1954).

(4) R. Livingston, J. Ghormley and H. Zeldes, *J. Chem. Phys.*, **24**, 483 (1956).

(5) E. D. Becker, G. C. Pimentel and M. Van Thiel, *ibid.*, **26**, 145 (1957).

(6) R. G. Sowden and N. Davidson, *THIS JOURNAL*, **78**, 1291 (1956).

(7) G. W. Robertson and M. McCarty, Jr., *J. Chem. Phys.*, **28**, 1271 (1958).

Experimental

The general technique is to deposit on a window at 20°K ., by effusion, a film of nitrogen or argon plus suitable reactive chemicals. These materials can be subjected to photolysis by ultraviolet light. The chemical changes are observed by infrared and ultraviolet spectrophotometry. Alternately, one can attempt to decompose the reactive chemical in the vapor phase and trap unstable species by rapid freezing.

The Low Temperature Cell.—The apparatus consists essentially of a windowed cold finger suspended in a vacuum chamber in such a manner that gases from storage vessels may be effused onto one of the cold windows. Normally two storage vessels are used, one containing an inert material (matrix) and the other containing the "active" material. The vacuum chamber is also fitted with windows. All connections to the vacuum chamber are demountable in order that the cell may be transported, without loss of vacuum, to the spectrophotometer.

The cell, which is suitable for use with liquid helium, hydrogen or nitrogen, is shown in half section in Fig. 1. The height is twenty-six inches, and the capacity of the central coolant vessel A is about 600 ml. The liquid nitrogen jacket B also has a volume of approximately 600 ml. The coolant containers are constructed of brass, the necks are of stainless steel, and the outer vacuum jacket is of aluminum. Vacuum seals in the outer jacket are made by means of O-rings.

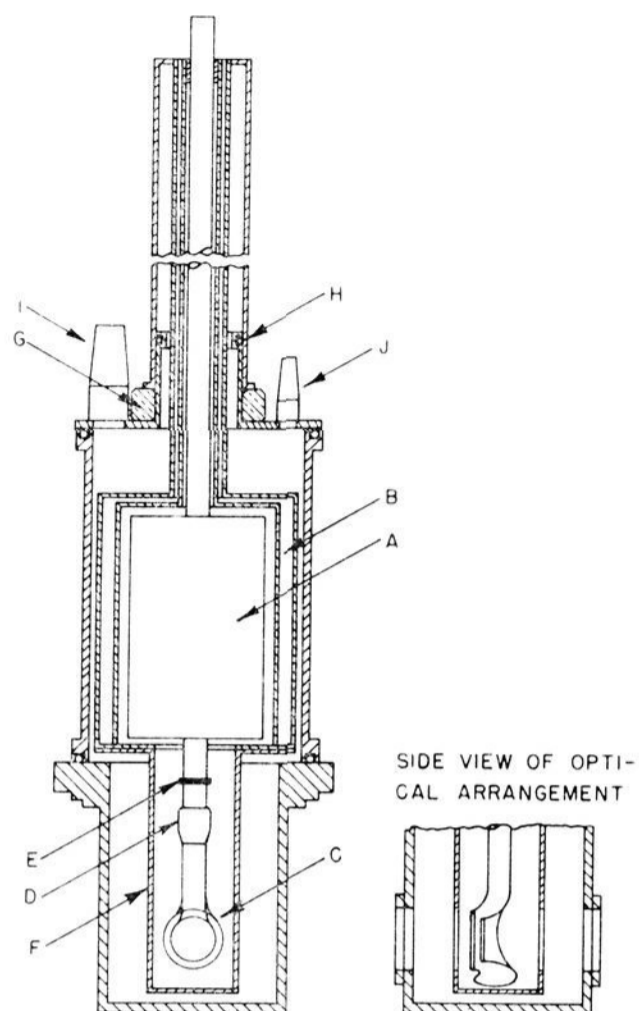

Fig. 1.—The low temperature cell (for explanation of letters, see text).

Silver soldering was used throughout except that the seal E is soft soldered to allow easy removal of the Pyrex part C. The aluminum shield F is removable to allow access to part C. The entire central assembly is mounted upon the thrust bearing G and may be rotated through any angle inside the vacuum chamber. The moving vacuum seal is accomplished by means of the O-ring H. The cell is evacuated through the metal standard taper I, and a pressure gauge may be attached at J for measurement of the pressure inside the cell.

The Pyrex section C is the optical cell; it has two ground surfaces to which one millimeter sapphire windows are cemented with Epibond 101 cement, obtained from the Furnace Plastics Company. The coefficient of thermal conductivity of sapphire at 20°K . is about $8 \text{ cal. cm.}^{-1} \text{ sec.}^{-1} \text{ deg.}^{-1}$; therefore, it is an excellent material for use at liquid hydrogen temperature. The rear window is inset so that the path length through the liquid coolant is reduced to about two millimeters, thus minimizing scattering by bubbles in the liquid.

The lower section of the vacuum jacket, shown in Fig. 2, has two windows which are aligned by rotation of the interior assembly with the windows of the optical cell. The rear window is quartz and is sealed in with Apiezon cement. The front window is sodium chloride and is sealed to an O-ring mount which permits it to be removed and stored in a desiccator when not in use. A similarly mounted quartz window is used when the infrared transmission of sodium chloride is not required. To the left of the front window may be seen the input through which the film materials are deposited. During effusion the cold finger is revolved to face the jets of gases which are being deposited. The inert medium is brought in through the stopcock and copper tube, and the "active" material flows in through the high speed duct, which may be sealed off under vacuum by seating a plunger-carried cap upon the surrounding O-ring.

Spectrophotometry.—The cell is designed to fit directly into the Cary Model 11 M spectrophotometer in such a manner that the light beam passes through the windows of the vacuum chamber and cold finger. The sapphire window on which the sample is to be deposited has, as an outer annulus, an evaporated aluminum mirror. Infrared absorption spectra of the films were taken by reflection, using

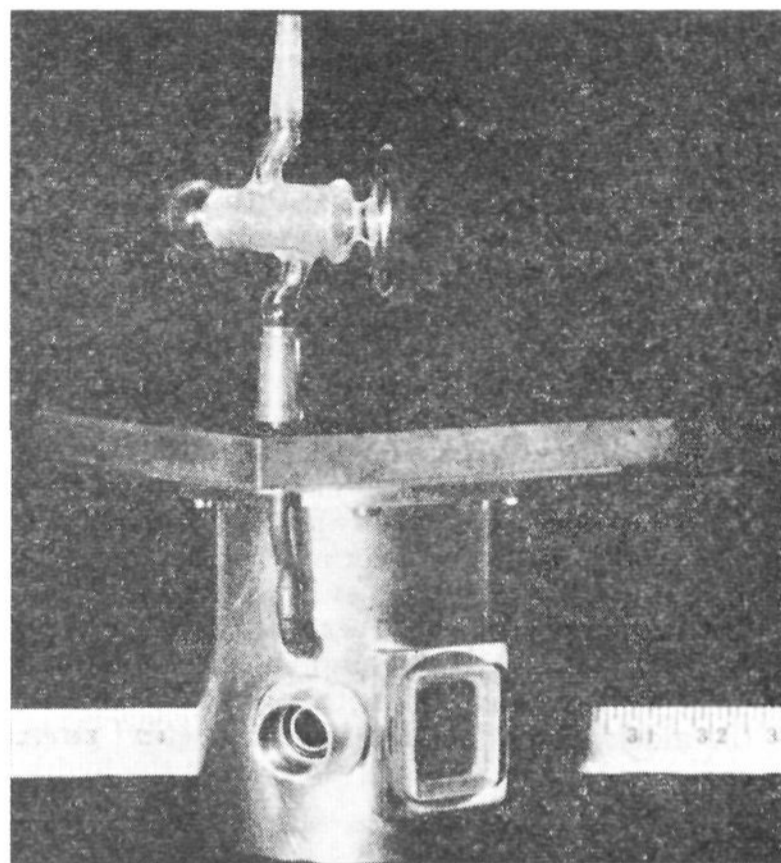

Fig. 2.—Lower section of the vacuum jacket.

the optical system shown in Fig. 3. The light beam from the infrared source housing is deflected at the plane mirror M_1 so that it passes through the front window of the cell. The converging beam passes through the sample film which is deposited on the cold mirror. After reflection from the cold mirror, the now diverging beam passes again through the film, out through the front window and impinges upon

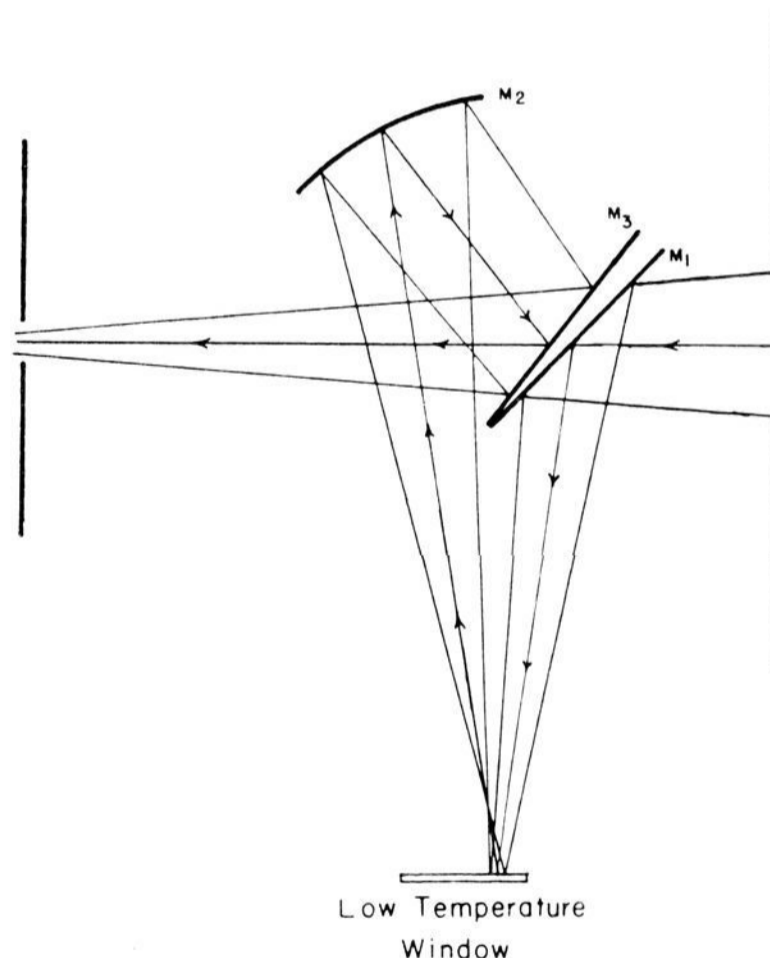

Fig. 3.—Optical system for infrared reflection spectra.

the concave spherical mirror M_2 , which has a radius of curvature of 17 cm. Mirror M_2 directs the beam, now converging, to the plane mirror M_3 , which deflects it into the entrance slit of the spectrophotometer.

With no film on the mirror, the infrared transmission of the system is about 65%. The transmission with a film depends on the scattering characteristics of the particular

(8) R. Berman, *Proc. Roy. Soc. (London)*, **A208**, 90 (1951).

material used; 40% is a typical value. The optical density for ultraviolet light of the hole in the mirror, on the Cary spectrophotometer, is about 0.1. Scattering from translucent films may be quite bad.

Absorption intensities in the infrared and, to a lesser extent, the visible-ultraviolet were used for following concentrations of reactants in the films. Beer's law has been assumed to hold but has not been checked rigorously. Concentration determinations by these methods can only be taken as order of magnitude calculations, but within this limitation they are useful. A suitable infrared band of each reactant was chosen, and a molar extinction coefficient was calculated from the input ratio of diluent to reactant and the film thickness as determined from the amount and density of diluent. Concentration depends only on the relative amount of reactant and diluent deposited, but the film thickness will be in error to the extent that the collection efficiency is less than unity. However, this error will be cancelled out when the extinction coefficient is used to determine an unknown concentration since the film thickness used in the calculation will contain the same error.

The above method was used in every case except for ozone, for which it was difficult to determine accurately the quantity effused into the films. An extinction coefficient for the ν_2 band of ozone was calculated, therefore, from absorption in the ultraviolet, taking advantage of the known vapor phase absorption coefficients in this region⁹ and assuming that they would be approximately applicable in the low temperature medium.

Chemicals.—For the preparation of ozone, tank oxygen was passed over P_2O_5 and into a small laboratory ozonizer of the type described by Yost and Russell.¹⁰ The effluent gases were passed through a liquid nitrogen trap, at which point a blue solution of ozone in liquid oxygen collected. The bulk of the oxygen was removed by lowering the liquid nitrogen level and allowing it to boil off, and the ozone was used without further purification.

Tank nitrogen dioxide (Matheson) was passed over P_2O_5 and collected at -10° . Dry oxygen was bubbled through to remove NO, and the NO_2 then was passed through a second P_2O_5 tube and collected at -78° .

Nitrous oxide was prepared by thermal decomposition of ammonium nitrate. The gaseous products were bubbled through a ferrous sulfate solution to remove NO and sublimed from -78° to remove water.

Photolysis.—An Osram HBO 200-watt high pressure mercury arc was used as a source. The arc was located at a distance of about ten cm. from the film, and a circulating water filter was used to minimize heating of the film during irradiation. With this arrangement the temperature rise in the film was found to be approximately 3° at liquid nitrogen temperature and 8° at liquid hydrogen temperature.

Results

Reaction of Oxygen Atoms with Nitrogen.—

Figure 4 (upper trace) shows the spectrum of a 1.5 M film of ozone in nitrogen at $20^\circ K$. (M means mole liter⁻¹). The spectrum is in close agreement with the vapor phase spectrum reported by Wilson and Badger.¹¹ The lower trace shows the result of 30 minutes of irradiation with the mercury arc. The ozone concentration has been reduced to 0.89 M, and well-defined bands have appeared at 2222 and 1290 cm^{-1} . By comparison with the vapor phase spectrum, these bands were identified as ν_3 and ν_1 , respectively, of nitrous oxide. The identification was checked by preparation of known films of nitrous oxide prepared from ammonium nitrate.

Data on nitrous oxide yield in four ozone photolysis experiments is presented in Table I. The percentage yield appears to decrease with increasing initial ozone concentration in agreement

(9) A. Läuchle, *Z. Physik*, **53**, 92 (1929).

(10) D. M. Yost and H. Russell, Jr., "Systematic Inorganic Chemistry," Prentice-Hall, Inc., New York, N. Y., 1946, p. 262.

(11) M. K. Wilson and R. M. Badger, *J. Chem. Phys.*, **16**, 741 (1948).

TABLE I

Initial (O ₃) (M)		Final		N ₂ O produced (M)	Yield %
1.45	0.89	0.036	6		
0.59	.20	.05	13		
.22	.02	.07	35		
.21	.10	.03	27		

The reaction



with the expectation that there will be competition between reaction with nitrogen to form nitrous oxide and the reaction

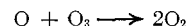

is endothermic by 38.3 kcal., and the activation energy for the decomposition is estimated by different authors as 53^{12} to 60^{13} kcal. The activation energy barrier for the reverse reaction, therefore, is between 15 and 22 kcal. Possible dissociation curves for N_2O are shown in Fig. 5. It is not

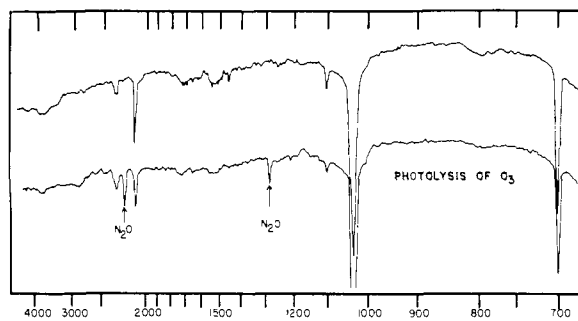

Fig. 4.—Infrared spectra for photolysis of ozone (1.5 M) in a nitrogen matrix; upper and lower traces, before and after irradiation, respectively.

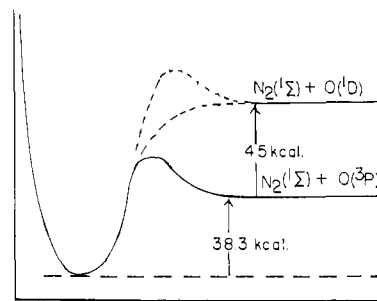

Fig. 5.—Dissociation curves for N_2O .

known whether or not there is a barrier for the reaction of $O(^1D)$ atoms with N_2 , although it is assumed by many authors that there is none. At least the spin conservation rule is not violated by the reaction of $O(^1D)$ with $N_2(^1\Sigma)$ to give $N_2O(^1\Sigma)$, whereas it is for $O(^3P)$. The transmission coefficient situation where the curves cross is discussed by Stearns and Eyring.¹⁴

The formation of N_2O is clearly a hot atom reaction, but it is not certain whether the excess energy of the O atom is translational or electronic. The energies of several pertinent reactions which

(12) P. Hartek and S. Dondes, *ibid.*, **22**, 758 (1954).

(13) H. S. Johnston, *ibid.*, **19**, 663 (1951).

(14) A. Stearns and H. Eyring, *ibid.*, **3**, 778 (1935).

obey the spin conservation rules are

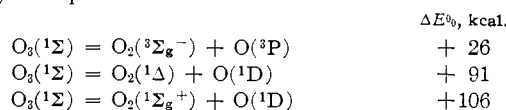

The second and third reactions require light such that $\lambda < 3100$ and 2680 \AA. , respectively. There is evidence that $\text{O}(^1\text{D})$ atoms are indeed produced by ultraviolet photolysis of ozone.¹⁵ Thus, it is plausible to believe that N_2O is formed by the reaction of $\text{O}(^1\text{D})$ atoms with N_2 , rather than by the reaction of translationally hot $\text{O}(^3\text{P})$ atoms; but this conclusion is not certain. It also should be noted that Harteck and Dondes¹² report the formation of N_2O in the thermal decomposition at 295° of O_3 in excess N_2 . A conversion efficiency of 10^{-4} was obtained. Nitrous oxide is formed in low yield when a gas phase mixture of nitrogen and oxygen is irradiated with the xenon resonance lines, 1470 and 1295 \AA. ¹⁶ This irradiation produces one $\text{O}(^3\text{P})$ and one $\text{O}(^1\text{D})$ atom, each, with some excess kinetic energy, so that it does not resolve the question of the mechanism of formation of N_2O .

Experiments were carried out using NO_2 instead of ozone as a source of oxygen atoms. It is known from separate experiments that NO_2 is photolyzable under the conditions of these experiments and that oxygen atoms are produced. If molecular oxygen is present in the film, ozone is formed according to the reaction

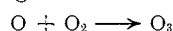

which has an activation energy of zero.¹⁷ N_2O formation was detected upon photolysis of NO_2 either with a Pyrex filter or with the full light of the high pressure mercury arc. This result can be taken as evidence that ^3P oxygen atoms without much excess translational energy are not effective in the oxidation of nitrogen to nitrous oxide since it is quite certain that ground state oxygen atoms are produced by light of wave length greater than 2450 \AA. Failure of N_2O to appear upon photolysis with the full light of the arc does not, however, indicate that ^1D atoms are also ineffective since there is no evidence that a significant number of ^1D atoms are produced. One of the difficulties is that traces of N_2O_4 were present in the film in this experiment; the strong absorption by this species around 2450 probably interfered with the photolysis of NO_2 at this wave length.

It should be noted at this point that when films were deposited from gas mixtures with a $\text{N}_2:\text{NO}_2$ ratio of 50, comparable quantities of NO_2 and N_2O_4 were present. If the $\text{N}_2:\text{NO}_2$ ratio was 800, only traces of N_2O_4 were present.

Reaction of Oxygen Atoms with Nitrogen Dioxide.—Irradiation of nitrogen films containing ozone and nitrogen dioxide results in the following products: N_2O_5 , NO , N_2O and NO_3 . With the exception of NO_3 , all were identified by their absorption in the infrared. The NO_3 was not obtained in quantity sufficient for infrared detection.

(15) W. D. McGrath and R. G. W. Norrish, *Nature*, **182**, 235 (1958).

(16) W. E. Groth and H. Schierholz, *J. Chem. Phys.*, **27**, 973 (1957).

(17) S. W. Benson and A. E. Axworthy, Jr., *ibid.*, **26**, 1718 (1957).

The infrared spectra of the oxides of nitrogen in low temperature matrices are complex, and care must be exercised in the identification of absorption bands of the various species and in the use of these bands to determine concentrations. The infrared bands used for identification of the several species and some of the extinction coefficients used for concentration calculations are given in Table II.

TABLE II
INFRARED BANDS AND EXTINCTION COEFFICIENTS

Species	Band frequency (cm. ⁻¹)	Identification	Decadic molar extinction coefficient
NO_2	1620	ν_3	280 ± 75
	750	ν_2	20 ± 10
N_2O	2222	ν_3	$67(\pm 10)$
N_2O_5	1745		$230(\pm 100)$
	737		$460(\pm 200)$
O_3	702	ν_2	11
N_2O_4	1767		
	1743		
	1250-1300		(weak)

The NO_3 radical was identified by its absorption spectrum in the visible region. In the vapor state, the visible spectrum consists of strong, well-defined bands at 662 and $624 \text{ m}\mu$, and weaker, more diffuse bands in the $500\text{--}600 \text{ m}\mu$ region.¹⁸ The absorption coefficients of the two strong bands of NO_3 have been estimated to be of the order of $3000 \text{ M}^{-1} \text{ cm.}^{-1}$.¹⁹

In our experiments NO_3 has been produced and isolated by three methods: reaction of oxygen atoms with NO_2 in the matrix, vapor phase photolysis of N_2O_5 and trapping the products from an electric discharge through a mixture of NO_2 and O_2 . Figure 6 shows the spectrum of NO_3 (NO_2 also present) at 20°K. The two intense maxima are found at 666 and $629 \text{ m}\mu$. The lower trace is the spectrum of NO_3 and NO_2 produced by vapor phase photolysis of N_2O_5 . The N_2O_5 was passed through a quartz irradiation tube, and the products were trapped in a nitrogen film containing about 15% O_3 and 15% O_2 . The ratio of N_2O_5 to total diluent was 1:140, and the input of N_2O_5 was 8×10^{-5} mole. The film then was irradiated 20 minutes through a $\text{NiSO}_4\text{--CoSO}_4$ filter; the spectrum after irradiation is shown by the upper trace of Fig. 6. The NO_3 concentration increased by a factor of nearly two, and the concentration of NO_3 was estimated to be about $2 \times 10^{-8} \text{ M}$, taking $\epsilon_{666} = 3000 \text{ M}^{-1} \text{ cm.}^{-1}$.

The major reactions which occur upon photolysis of ozone- NO_2 films are

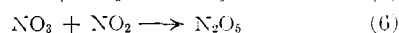
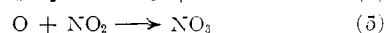
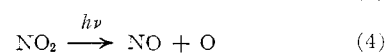
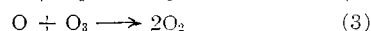
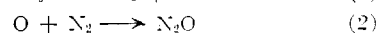
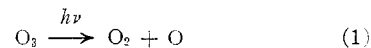

The N_2O_5 is formed in amounts comparable to NO_3 in high dilution experiments; but at higher NO_2 and O_3 concentrations, it becomes the major product.

(18) J. Jones and O. R. Wulf, *ibid.*, **5**, 873 (1937).

(19) G. I. Schott and N. Davidson, *THIS JOURNAL*, **80**, 1811 (1958).

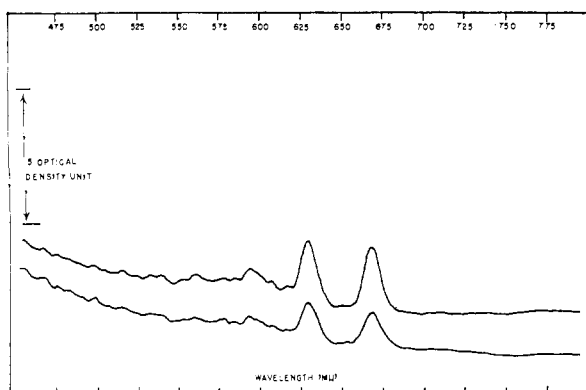
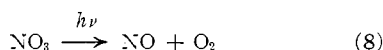
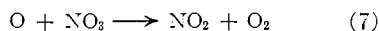

Fig. 6.—Absorption spectrum of frozen preparations of NO_3 .

In Fig. 7 the time histories of the concentrations of NO_2 , O_3 , NO , N_2O , N_2O_5 and NO_3 during photolysis are shown. The final nitric oxide concentration was calculated by material balance, and the intermediate NO concentrations were calculated from the relative densities of the NO band.

As photolysis proceeds, the NO_3 concentration does not follow the N_2O_5 concentration but always reaches a maximum value and then decreases with continuing irradiation. Loss of NO_3 by reaction with NO_2 should diminish as the NO_2 concentration decreases since the dilution with respect to NO_2 is increasing. The time behavior of NO_3 indicates that it is being destroyed by other processes, the most likely of which are



Photolytic destruction of NO_3 may be expected to play an increasingly important role in later stages of photolysis.

The N_2O_5 in the film does not react with oxygen atoms and does not photolyze.

The Reaction of Oxygen Atoms with Nitrous Oxide.—For many years there has been controversy about the origin of nitric oxide in the thermal and photochemical decomposition of nitrous oxide. Of the two possible initial steps

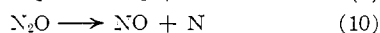

the latter has been ruled out in the thermal decomposition²⁰ and is believed to occur in photolysis only at very short wave length (1236 Å).²¹ Nitric oxide must then be formed by the reaction

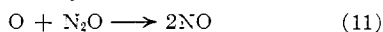

Noyes and co-workers²² were unable to detect any reaction with nitrous oxide of ^1D or ^3P oxygen atoms produced by photolysis of nitrogen dioxide in the vapor and concluded that the reaction was too slow to compete with recombination of oxygen on the walls in nitrous oxide photolysis.

Kistiakowsky and Volpi²³ found the rate constant of the reaction for ^3P atoms to be less than 2×10^8

(20) L. Friedman and J. Bigeleisen, *THIS JOURNAL*, **75**, 2215 (1953).

(21) M. Zelikoff and L. M. Aschenbrand, *J. Chem. Phys.*, **27**, 123 (1957).

(22) F. C. Henriques, A. B. F. Duncan and W. A. Noyes, *ibid.*, **6**, 518 (1938).

(23) G. B. Kistiakowsky and G. G. Volpi, *ibid.*, **27**, 1141 (1957).

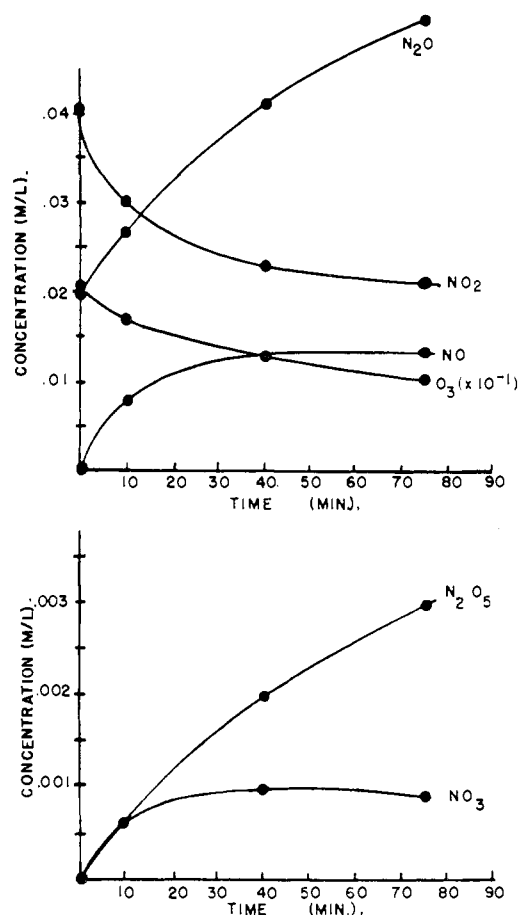

Fig. 7.—Photolysis of ozone-nitrogen dioxide films.

cc. mole⁻¹ sec.⁻¹ at room temperature. Kaufman, *et al.*,²⁴ estimate a rate constant for $\text{O}(^3\text{P})$ atoms for reaction 11 of $k = 10^{11} \exp(-15,500/RT)$ cc. mole⁻¹ sec.⁻¹.

The reaction of oxygen atoms with nitrous oxide in photolyses at 1049 and 1470 Å. may actually involve ^1S atoms rather than ^1D or ^3P .²⁵

We have found that oxides of nitrogen are produced when ozone is photolyzed in the presence of nitrous oxide at 20°K. A film of nitrogen containing nitrous oxide at a concentration of 0.36 M and ozone at a concentration of 3.2 M was prepared and irradiated until the ozone concentration was reduced to 0.64 M . The infrared spectrum showed that NO_2 and N_2O_5 were formed at concentrations of approximately 0.02 and 0.05 M , respectively. The N_2O concentration increases slightly due to the reaction of oxygen atoms with nitrogen. The absence of NO is not unexpected in view of the excess ozone.

In the second experiment a film of nitrous oxide containing a small concentration of ozone was irradiated. The products were NO , NO_2 and N_2O_4 . The N_2O_5 was not formed in detectable amount. The yield of nitrogen oxides, on the basis of ozone decomposed, was at least five times greater than in the previous experiment, owing to the high ratio of nitrous oxide to ozone in this experiment.

(24) F. Kaufman, N. Gerri and R. Bowman, *ibid.*, **25**, 106 (1956).

(25) M. Zelikoff and L. M. Aschenbrand, *ibid.*, **22**, 1680 (1954).

Nitrogen oxides do not appear upon irradiation of similar films of nitrous oxide or ozone alone and must, therefore, be due to reactions such as

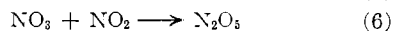
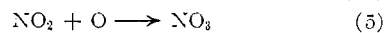
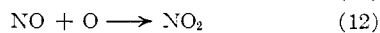
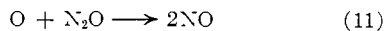
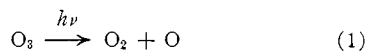

The reaction

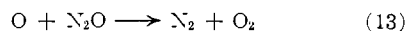

would not have been detected.

Discussion

In many respects, the results presented in the preceding section speak for themselves. Several points deserve further comment, however.

In the first place, it is clear that free radicals can be trapped in the nitrogen matrix. Thus, NO_3 and NO_2 have been trapped, although there is no energy barrier to their combination or to the combination of two NO_2 molecules. However, evaporation of mixtures of NO_2 and N_2 at low dilutions (1:50) gives large quantities of N_2O_4 . Thus, it appears that on condensation molecules retain their mobility for a short period of time before being frozen.

It is also clear, however, that hot atom chemistry and phenomena of local melting are of vital importance for the photochemistry of these rigid media.

The significance of hot atom chemistry in the formation of N_2O has already been discussed. There are several significant examples of local melting phenomena. Thus, the formation of NO_3 probably requires that the O atom photoejected from O_3

wander around for a short while until it finds an NO_2 . Similarly, the formation of N_2O_5 from NO_2 and O atoms (N_2O_4 being essentially absent in these experiments) implies that when an O atom adds on to NO_2 (reaction 5), the heat of reaction (~ 50 kcal.) produces local melting so that the NO_3 can diffuse and possibly combine with an NO_2 molecule. In the photolysis of O_3 in N_2 , there is more O_3 decomposed than N_2O formed. We believe (although positive evidence as to this point is lacking) that the O atoms that did not form N_2O were not stored as free atoms but reacted with O_3 to give 2O_2 (reaction 3). This reaction has an activation energy of ~ 5 kcal., so again hot atom chemistry and local diffusion are involved if it occurs at 20°K .

The local melting phenomenon may be discussed briefly as follows. With a heat of reaction of 50 kcal. mole $^{-1}$, one atom of O reacting with NO_2 produces enough heat to melt a sphere of nitrogen of radius *ca.* 140 Å. The heat diffusivity of liquid nitrogen does not seem to be known, but it is probably about 10^{-3} cm. 2 sec. $^{-1}$. According to the relation, $X^2 \sim Dt$, the time before this region will freeze and cool down is of the order of 2×10^{-9} sec. The volume melted ($\sim 10^{-17}$ cc.) would contain 10^2 NO_2 molecules if the concentration were 0.01 M, so there is at least a fair chance that the NO_3 molecule will react with another NO_2 to give N_2O_5 .

Acknowledgments.—We are indebted to the National Science Foundation for support. We have profited greatly by discussions with Dr. O. R. Wulf and Dr. R. M. Badger. The optics for the infrared reflecting system are based on a design by Dr. R. M. Badger and Mr. N. Albert.

PASADENA, CALIFORNIA

[CONTRIBUTION NO. 2451 FROM THE GATES AND CRELLIN LABORATORIES OF CHEMISTRY, CALIFORNIA INSTITUTE OF TECHNOLOGY]

Photochemical Experiments in Rigid Media at Low Temperatures. II. The Reactions of Methylene, Cyclopentadienylene and Diphenylmethylene

BY WILLIAM B. DEMORE, H. O. PRITCHARD AND NORMAN DAVIDSON

RECEIVED MARCH 31, 1959

The photolysis of several diazo compounds in rigid matrices at low temperatures has been studied by ultraviolet-visible and by infrared spectrophotometry. Photolysis of CH_2N_2 in a nitrogen matrix at 20°K . gives a complex mixture including C_2H_4 , cyclopropane and various stable and unstable unidentified species. CH_2 may have been present, but it could not be positively identified. Some of the products probably are due to the reaction of CH_2 with CH_2N_2 . When CH_2N_2 is photolyzed in a CO, N_2 matrix, CH_2CO is formed by the reaction, $\text{CH}_2 + \text{CO} \rightarrow \text{CH}_2\text{CO}$. In the presence of C_2H_4 , cyclopropane is formed ($\text{CH}_2 + \text{C}_2\text{H}_4 \rightarrow \text{C}_3\text{H}_4$). There is pretty good evidence for the reaction $\text{CH}_2 + \text{CH}_2\text{CO} \rightarrow$ cyclopropanone. Photolysis of diazocyclopentadiene in a fluorocarbon ether matrix at 77°K . or in a nitrogen matrix at 20°K .

(but not in a hydrocarbon matrix at 77°K .) gives fulvalene,

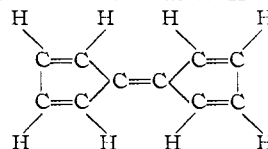

Photolysis of diphenyldiazomethane in nitrogen at 20°K . or in the fluorocarbon at 77°K . evidently gives principally, $(\text{C}_6\text{H}_5)_2\text{C}=\text{N}-\text{N}=\text{C}(\text{C}_6\text{H}_5)_2$, benzophenone azine. Diphenyl ketene is *not* formed by the photolysis of $(\text{C}_6\text{H}_5)_2\text{CN}_2$ in the presence of excess CO. Photolysis of $(\text{C}_6\text{H}_5)_2\text{CN}_2$ in the presence of O_2 gives benzophenone.

We have endeavored to prepare several methylene type radicals, R_2C , by photodecomposition of the corresponding diazo compounds trapped in a

rigid matrix at 77 or 20°K . The products are observed by ultraviolet-visible and infrared spectrophotometry. In no case have we been able to